

# BOSTITCH®

## F21PL / F21PL2 / F28WW F33PT / F33PTSM

**PNEUMATIC STICK NAILER**  
**CLAVADORA NEUMÁTICA ALIMENTADA POR BARRA**  
**CLOUEUR PNEUMATIQUE À CARTOUCHE**



### **OPERATION and MAINTENANCE MANUAL** **MANUAL DE OPERACIÓN Y DE MANTENIMIENTO** **MANUEL D'INSTRUCTIONS ET D'ENTRETIEN**

**⚠ WARNING:**

**⚠ ADVERTENCIA:**

**⚠ ATTENTION:**

BEFORE OPERATING THIS TOOL, ALL OPERATORS SHOULD STUDY THIS MANUAL TO UNDERSTAND AND FOLLOW THE SAFETY WARNINGS AND INSTRUCTIONS. KEEP THESE INSTRUCTIONS WITH THE TOOL FOR FUTURE REFERENCE. IF YOU HAVE ANY QUESTIONS, CONTACT YOUR BOSTITCH REPRESENTATIVE OR DISTRIBUTOR.

ANTES DE OPERAR ESTA HERRAMIENTA, TODOS LOS OPERADORES DEBERÁN ESTUDIAR ESTE MANUAL PARA PODER COMPRENDER Y SEGUIR LAS ADVERTENCIAS SOBRE SEGURIDAD Y LAS INSTRUCCIONES. MANTENGA ESTAS INSTRUCCIONES CON LA HERRAMIENTA PARA FUTURA REFERENCIA, SI TIENE ALGUNA DUDA, COMUNÍQUESE CON SU REPRESENTANTE DE BOSTITCH O CON SU DISTRIBUIDOR.

LIRE ATTENTIVEMENT LE PRÉSENT MANUEL AVANT D'UTILISER L'APPAREIL. PRÊTER UNE ATTENTION TOUTE PARTICULIÈRE AUX CONSIGNES DE SÉCURITÉ ET AUX AVERTISSEMENTS. GARDER CE MANUEL AVEC L'OUTIL POUR FUTUR RÉFÉRENCE. SI VOUS AVEZ DES QUESTIONS, CONTACTEZ VOTRE REPRÉSENTANT OU VOTRE CONCESSIONNAIRE BOSTITCH.

**BOSTITCH®**  
STANLEY FASTENING SYSTEMS L.P.

# INTRODUCTION

---

BOSTITCH tools are precision-built tools, designed for precise, high volume nailing. These tools will deliver efficient, dependable service when used correctly and with care. As with any fine power tool, for best performance the manufacturer's instructions must be followed. Please study this manual before operating the tool and understand the safety warnings and cautions. The instructions on installation, operation and maintenance should be read carefully, and the manual kept for reference. NOTE: Additional safety measures may be required because of your particular application of the tool. Contact your BOSTITCH representative or distributor with any questions concerning the tool and its use. BOSTITCH, East Greenwich, Rhode Island 02818.

# INDEX

---

Safety Instructions .....	3
Tool Specifications .....	4
Air Supply: Fittings, Hoses, Filters, Air Consumption, Regulators, Operating Pressure, Setting Correct Pressure .....	4, 5
Lubrication .....	5
Loading the Tool, .....	6
Guide Rod installation .....	6
Fastener Depth Control Adjustment .....	7
Removing Nails, Directional Exhaust .....	7
Installing the metal connector attachment .....	8
Tool Operation .....	9,10, 11 &12
Maintaining the Pneumatic Tool .....	13
Trouble Shooting .....	14

# NOTE:

---

BOSTITCH tools have been engineered to provide excellent customer satisfaction and are designed to achieve maximum performance when used with precision BOSTITCH fasteners engineered to the same exacting standards. **The F33PT or F33PTSM, with the standard framing contact arm is designed for use with 33° paper tape stick nails. The F33PT or F33PTSM, with the Metal Connector Attachment installed is designed for use with BOSTITCH 35° metal connector nails. The F21PL & F21PL2 with the standard framing contact arm is designed for use with 21° plastic collated stick nails. The F21PL & F21PL2, with the optional Metal Connector Attachment installed is designed for use with BOSTITCH 23° metal connector nails. BOSTITCH cannot assume responsibility for product performance if our tools are used with fasteners or accessories not meeting the specific requirements established for genuine BOSTITCH nails, staples and accessories.**



# LIMITED WARRANTY – U.S. and Canada Only

---

Effective December 1, 2005 Bostitch, L.P. warrants to the original retail purchaser that the product purchased is free from defects in material and workmanship, and agrees to repair or replace, at Bostitch's option, any defective Bostitch branded pneumatic stapler or nailer for a period of seven (7) years from date of purchase (one (1) year from the date of purchase for compressors and tools used in production applications). Warranty is not transferable. Proof of purchase date required. This warranty covers only damage resulting from defects in material or workmanship; it does not cover conditions or malfunctions resulting from normal wear, neglect, abuse, accident or repairs attempted or made by other than our national repair center or authorized warranty service centers. Driver blades, bumpers, o-rings, pistons and piston rings are considered normally wearing parts. For optimal performance of your Bostitch tool always use genuine Bostitch fasteners and replacement parts.

THIS WARRANTY IS IN LIEU OF ALL OTHER WARRANTIES, EXPRESS OR IMPLIED, INCLUDING BUT NOT LIMITED TO THE IMPLIED WARRANTIES OF MERCHANTABILITY OR FITNESS FOR A PARTICULAR PURPOSE. BOSTITCH SHALL NOT BE LIABLE FOR ANY INCIDENTAL OR CONSEQUENTIAL DAMAGES.

Some states and countries do not allow limitations on how long an implied warranty lasts, or the exclusion or limitation of incidental or consequential damages, so the above limitations or exclusions may not apply to you. This warranty gives you specific legal rights, and you may also have other rights which vary from state to state and country to country.

To obtain warranty service in the U.S. return the product, together with proof of purchase, to the U.S. Bostitch National or Regional Independent Authorized Warranty Service Center. In the U.S. you may call us at 1-800-556-6696 or visit [www.BOSTITCH.com](http://www.BOSTITCH.com) for the location most convenient for you. In Canada please call us at 1-800-567-7705 or visit [www.BOSTITCH.com](http://www.BOSTITCH.com)

## SAFETY INSTRUCTIONS

**⚠WARNING:** **EYE PROTECTION** which conforms to ANSI specifications and provides protection against flying particles both from the FRONT and SIDE should ALWAYS be worn by the operator and others in the work area when connecting to air supply, loading, operating or servicing this tool. Eye protection is required to guard against flying fasteners and debris, which could cause severe eye injury.



The employer and/or user must ensure that proper eye protection is worn. Eye protection equipment must conform to the requirements of the American National Standards Institute, ANSI Z87.1 and provide both frontal and side protection. NOTE: Non-side shielded spectacles and face shields alone do not provide adequate protection.



**⚠CAUTION:** Additional Safety Protection will be required in some environments. For example, the working area may include exposure to noise level which can lead to hearing damage. The employer and user must ensure that any necessary hearing protection is provided and used by the operator and others in the work area. Some environments will require the use of head protection equipment. When required, the employer and user must ensure that head protection conforming to ANSI Z89.1 is used.

## AIR SUPPLY AND CONNECTIONS

**⚠WARNING:** Do not use oxygen, combustible gases, or bottled gases as a power source for this tool as tool may explode, possibly causing injury.

**⚠WARNING:** Do not use supply sources which can potentially exceed 200 P.S.I.G. as tool may burst, possibly causing injury.

**⚠WARNING:** The connector on the tool must not hold pressure when air supply is disconnected. If a wrong fitting is used, the tool can remain charged with air after disconnecting and thus will be able to drive a fastener even after the air line is disconnected possibly causing injury.

**⚠WARNING:** Do not pull trigger or depress contact arm while connected to the air supply as the tool may cycle, possibly causing injury.

**⚠WARNING:** Always disconnect air supply: 1.) Before making adjustments; 2.) When servicing the tool; 3.) When clearing a jam; 4.) When tool is not in use; 5.) When moving to a different work area, as accidental actuation may occur, possibly causing injury.

## LOADING TOOL

**⚠WARNING:** When loading tool: 1.) Never place a hand or any part of body in fastener discharge area of tool; 2.) Never point tool at anyone; 3.) Do not pull the trigger or depress the trip as accidental actuation may occur, possibly causing injury.

## OPERATION

**⚠WARNING:** Always handle the tool with care: 1.) Never engage in horseplay; 2.) Never pull the trigger unless nose is directed toward the work; 3.) Keep others a safe distance from the tool while tool is in operation as accidental actuation may occur, possibly causing injury.

**⚠WARNING:** The operator must not hold the trigger pulled on contact arm tools except during fastening operation as serious injury could result if the trip accidentally contacted someone or something, causing the tool to cycle.

**⚠WARNING:** Keep hands and body away from the discharge area of the tool. A contact arm tool may bounce from the recoil of driving a fastener and an unwanted second fastener may be driven possibly causing injury.

**⚠WARNING:** Check operation of the contact arm mechanism frequently. Do not use the tool if the arm is not working correctly as accidental driving of a fastener may result. Do not interfere with the proper operation of the contact arm mechanism.

**⚠WARNING:** Do not drive fasteners on top of other fasteners or with the tool at an overly steep angle as this may cause deflection of fasteners which could cause injury.

**⚠WARNING:** Do not drive fasteners close to the edge of the work piece as the wood may split, allowing the fastener to be deflected possibly causing injury.

**⚠WARNING:** This nailer produces SPARKS during operation. NEVER use the nailer near flammable substances, gases or vapors including lacquer, paint, benzene, thinner, gasoline, adhesives, mastics, glues or any other material that is – or the vapors, fumes or byproducts of which are – flammable, combustible or explosive. Using the nailer in any such environment could cause an EXPLOSION resulting in personal injury or death to user and bystanders.

**⚠WARNING:** Never use rafter hook to hang tool from body, clothing or belt.

## MAINTAINING THE TOOL

**⚠WARNING:** When working on air tools note the warnings in this manual and use extra care when evaluating problem tools.

# F SERIES TOOL SPECIFICATIONS

All screws and nuts are metric.

MODEL	TOOL ACTUATION	LENGTH	HEIGHT	WIDTH	WEIGHT
F28WW	Sequential Trip with Contact Trip Option	20" (508mm)	14" (355mm)	5-1/4" (133mm)	7.8 lb. (3.5 kg.)
F21PL	Sequential Trip with MCN and Contact Trip Option	20-3/8" (517mm)	14" (355mm)	5-1/4" (133mm)	8.1 lb. (3.7 kg.)
F21PL2	Sequential Trip with Contact Trip Option	20-3/8" (517mm)	14" (355mm)	5-1/4" (133mm)	8.1 lb. (3.7 kg.)
F33PT	Sequential Trip with MCN and Contact Trip Option	18" (457mm)	14" (355mm)	5-1/4" (133mm)	8.0 lb. (3.6 kg.)
F33PTSM	Sequential Trip with MCN and Contact Trip Option	14-3/16" (360mm)	14" (355mm)	5-1/4" (133mm)	7.9 lb. (3.6 kg.)

## FASTENER SPECIFICATIONS:

**F28WW:** Uses a 28° wire collated stick nail in lengths of 2" to 3-1/2" (50 - 90mm) and shank diameters of .113" to .131" (2.8 - 3.3mm)

### F21PL/F21PL2:

- **with standard framing contact arm installed:** Uses a 21° plastic collated full round head stick nails, in lengths of 2" to 3-1/2" (50-90mm) and shank diameters of .113" to .162" (2.8 - 4.1mm)
- **(Included with F21PL ONLY) with metal connector attachment installed:** Uses a 23° plastic collated full round head metal connector nails, in lengths of 1-1/2" and 2-1/2" (38 - 64mm) and shank diameters of .131", .148" and .162".
- MCN-KIT3 must be purchased separately for the F21PL2 to be used for fastening metal connectors.

**NOTE: Use only one stick of metal connector nails at a time.**

### F33PT/ F33PTSM:

- **with standard framing contact arm installed:** Uses a 33° paper collated stick nails, in lengths of 2" to 3-1/2" (50-90mm) and shank diameters of .113" to .131" (2.8 - 3.3mm)
- **with metal connector attachment installed:** Uses a 35° paper collated full round head metal connector nails, in lengths of 1-1/2" and 2-1/2" (38 - 64mm) and shank diameters of .131", .148" and .162".

**NOTE: Use only one stick of metal connector nails at a time.**

## TOOL AIR FITTING:

This tool uses a 1/4" N.P.T. male plug. The inside diameter should be .275" (7mm) or larger. The fitting must be capable of discharging tool air pressure when disconnected from the air supply.

## OPERATING PRESSURE:

70 to 120 p.s.i.g. (4.9 to 8.4 kg/cm<sup>2</sup>). Select the operating pressure within this range for best fastener performance. **DO NOT EXCEED THIS RECOMMENDED OPERATING PRESSURE.**

## AIR CONSUMPTION:

The F21PL / F21PL2 / F28WW / F33PT / F33PTSM requires 8.7 cubic feet per minute (247 liters per minute) of free air to operate at the rate of 100 nails per minute, at 80 p.s.i. (5.6 kg/cm<sup>2</sup>). Take the actual rate at which the tool will be run to determine the amount of air required. For instance, if your fastener usage averages 50 nails per minute, you need 50% of the 8.7 c.f.m. (247 liters per minute) which is required to operate the tool at 100 nails per minute.

## OPERATION

BOSTITCH OFFERS TWO MODES OF OPERATION FOR THIS SERIES TOOL.

### SEQUENTIAL TRIP (Gray trigger):

The Sequential Trip requires the operator to hold the tool against the work surface before pulling the trigger. This makes accurate fastener placement easier, for instance on framing, toe nailing and crating applications. The Sequential Trip allows exact fastener placement without the possibility of driving a second fastener on recoil, as described under "Contact Trip". The Sequential Trip Tool has a positive safety advantage because it will not accidentally drive a second fastener if the tool is contacted against the work – or anything else – while the operator is holding the trigger pulled.

### CONTACT TRIP (Black trigger):

The common operating procedure on "Contact Trip" tools is for the operator to contact the work surface to actuate the trip mechanism while keeping the trigger pulled, thus driving a fastener each time the work is contacted. This will allow rapid fastener placement on many jobs, such as sheathing, decking and pallet assembly. All pneumatic tools are subject to recoil when driving fasteners. The tool may bounce, releasing the trip, and if unintentionally allowed to re-contact the work surface with the trigger still actuated (finger still holding trigger pulled) an unwanted second fastener will be driven.

## OPERATION (continued)

### MODEL IDENTIFICATION:

Refer to Operation Instructions on page 9 before proceeding to use this tool.

#### SEQUENTIAL TRIP

Identified by:

**GRAY TRIGGER**



#### CONTACT TRIP

Identified by:

**BLACK TRIGGER**



## AIR SUPPLY AND CONNECTIONS

**⚠WARNING:** Do not use oxygen, combustible gases, or bottled gases as a power source for this tool as tool may explode, possibly causing injury.

### FITTINGS:

Install a male plug on the tool which is free flowing and which will release air pressure from the tool when disconnected from the supply source.

### HOSES:

Air hoses should have a minimum of 150 p.s.i. (10.6 kg/cm<sup>2</sup>) working pressure rating or 150 percent of the maximum pressure that could be produced in the air system. The supply hose should contain a fitting that will provide "quick disconnecting" from the male plug on the tool.

### SUPPLY SOURCE:

Use only clean regulated compressed air as a power source for this tool. **NEVER USE OXYGEN, COMBUSTIBLE GASES, OR BOTTLED GASES, AS A POWER SOURCE FOR THIS TOOL AS TOOL MAY EXPLODE.**

### REGULATOR:

A pressure regulator with an operating pressure of 0 - 125 p.s.i. (0 - 8.79 KG/CM<sup>2</sup>) is required to control the operating pressure for safe operation of this tool. Do not connect this tool to air pressure which can potentially exceed 200 p.s.i. (14 KG/CM<sup>2</sup>) as tool may fracture or burst, possibly causing injury.

### OPERATING PRESSURE:

Do not exceed recommended maximum operating pressure as tool wear will be greatly increased. The air supply must be capable of maintaining the operating pressure at the tool. Pressure drops in the air supply can reduce the tool's driving power. Refer to "TOOL SPECIFICATIONS" for setting the correct operating pressure for the tool.

### FILTER:

Dirt and water in the air supply are major causes of wear in pneumatic tools. A filter will help to get the best performance and minimum wear from the tool. The filter must have adequate flow capacity for the specific installation. The filter has to be kept clean to be effective in providing clean compressed air to the tool. Consult the manufacturer's instructions on proper maintenance of your filter. A dirty and clogged filter will cause a pressure drop which will reduce the tool's performance.

## LUBRICATION

Frequent, but not excessive, lubrication is required for best performance. Use BOSTITCH Air Tool Lubricant, Mobil Velocite #10, or equivalent. Do not use detergent oil or additives as these lubricants will cause accelerated wear to the seals and bumpers in the tool, resulting in poor tool performance and frequent tool maintenance. Only a few drops of oil at a time is necessary. Too much oil will only collect inside the tool and will be noticeable in the exhaust cycle.

### COLD WEATHER OPERATION:

For cold weather operation, near and below freezing, the moisture in the air line may freeze and prevent tool operation. We recommend the use of BOSTITCH winter formula air tool lubricant or permanent antifreeze (ethylene glycol) as a cold weather lubricant.

**CAUTION:** Do not store tools in a cold weather environment to prevent frost or ice formation on the tools operating valves and mechanisms that could cause tool failure.

**NOTE:** Some commercial air line drying liquids are harmful to "O"-rings and seals – do not use these low temperature air dryers without checking compatibility.

# LOADING THE F SERIES TOOLS

**WARNING:** EYE PROTECTION which conforms to ANSI specifications and provides protection against flying particles both from the FRONT and SIDE should ALWAYS be worn by the operator and others in the work area when connecting to air supply, loading, operating or servicing this tool. Eye protection is required to guard against flying fasteners and debris, which could cause severe eye injury.



**WARNING:** The employer and/or user must ensure that proper eye protection is worn. Eye protection equipment must conform to the requirements of the American National Standards Institute, ANSI Z87.1 and provide both frontal and side protection. NOTE: Non-side shielded spectacles and face shields alone do not provide adequate protection.

## TO PREVENT ACCIDENTAL INJURIES:

- Never place a hand or any other part of the body in nail discharge area of tool while the air supply is connected.
- Never point the tool at anyone else.
- Never engage in horseplay.
- Never pull the trigger unless nose is directed at the work.
- Always handle the tool with care.
- Do not pull the trigger or depress the trip mechanism while loading the tool.

## F21PL, F21PL2, F28WW, F33PT, F33PTSM

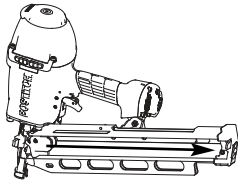

**1. Open the magazine:**  
Pull pusher back to engage the latch.

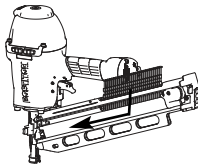

**2. Load Nails:** Hold nailer down with magazine tilted downward. Insert stick of nails

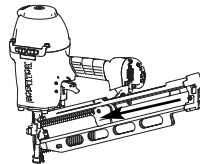

**3. Close Magazine:** Release pusher by first pulling back on the pusher and then pressing the pusher release tab. Slide pusher against nails.

**NOTE:** Use only nails recommended for use in BOSTITCH Framing nailers or nails which meet the BOSTITCH specifications.

**WARNING:** When installing metal connectors with the F21PL, F21PL2, F33PT or F33PTSM: use only one stick of metal connector nails at a time.

**WARNING:** Never use contact trigger (black trigger) with metal connector attachment. Only use sequential trigger (gray trigger) with metal connector attachment. Refer to trigger conversion instruction included in the kit.

**WARNING:** When installing Metal Connectors, use ONLY BOSTITCH Heat Treated Metal Connector Nails.

**WARNING:** Never use rafter hook to hang tool from body, clothing or belt.

## GUIDE ROD INSTALLATION AND REMOVAL F21PL, F21PL2, F33PT, F33PTSM TOOLS:

Fig. 1

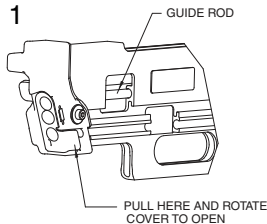

Fig. 2

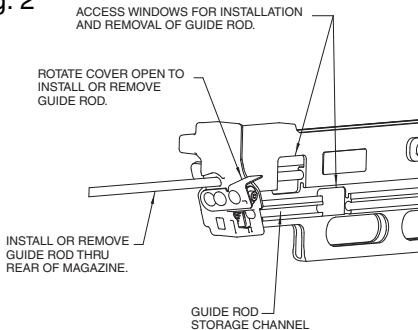
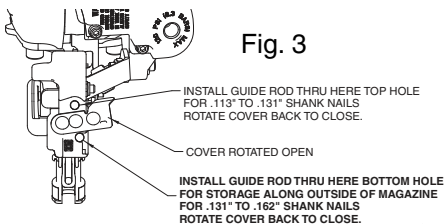

Fig. 3



# FASTENER DEPTH CONTROL ADJUSTMENT

## When using the framing contact arm:

The Fastener Depth Control Adjustment feature provides control of the nail drive depth from flush with or just above the work surface to shallow or deep countersink.

## TO ADJUST THE FASTENER DEPTH CONTROL:

**⚠WARNING:** Disconnect tool from air supply before attempting any parts disassembly and before changing the work contacting element adjustment.

1. Push in on locking button.
2. Adjust contact arm up to increase depth of drive or down to decrease it.
3. Release locking button

**Note:** Metal Connector Attachment is not adjustable for depth control.

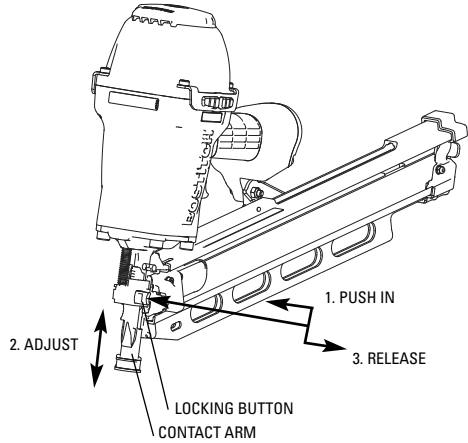

# DIRECTIONAL EXHAUST DEFLECTOR

The adjustable exhaust deflector can be rotated into any desired position by hand without the use of any tools.

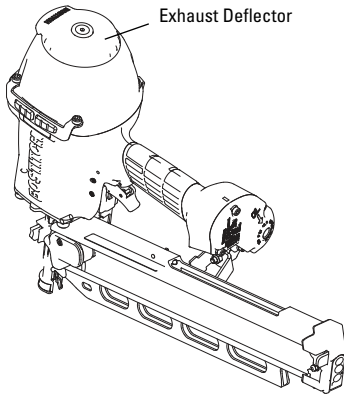

# REMOVING NAILS

1. Pull pusher back until it engages latch.
2. Slide nails back to opening and push out.

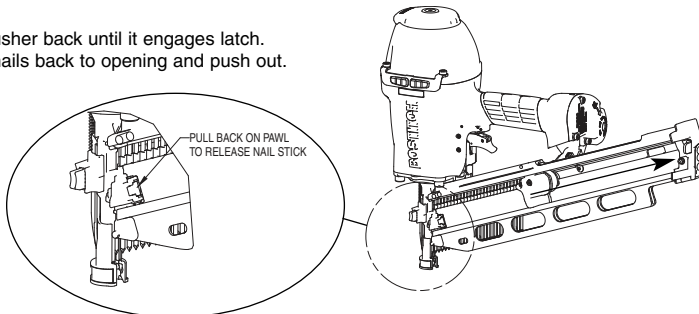

# INSTALLING THE METAL CONNECTOR ATTACHMENT KIT TO YOUR BOSTITCH F21PL / F21PL2 / F33PT / F33PTSM

**⚠WARNING:** Disconnect tool from air supply before attempting any parts disassembly and before changing the work contacting element.

**⚠WARNING:** Never use contact trigger (black trigger) with metal connector attachment. Only use sequential trigger (gray trigger) with metal connector attachment. Refer to trigger conversion instruction included in the kit.

**⚠WARNING:** When installing Metal Connectors, use ONLY BOSTITCH Heat Treated Metal Connector Nails

- Push in locking button.(See figure 1)
- Slide contact arm down until it easily detaches from the tool.
- Push in locking button and fully slide Metal Connector Attachment onto tool as shown in figure 2.
- Release Locking Button.
- Make sure that Metal Connector attachment is installed in the full up -position and that the locking button has returned to the released position.

**NOTE:** The Metal Connector Attachment is not adjustable for depth control.

- MCN-KIT3 must be purchased separately for the F21PL2 to be used for fastening metal connectors.
- Check that the Metal Connector Attachment now moves freely up and down. If not, **DO NOT USE**. Have tool and Metal Connector Attachment serviced by an authorized service center.
- Reverse procedure to remove Metal Connector Attachment and to install standard framing Lower Contact Arm.

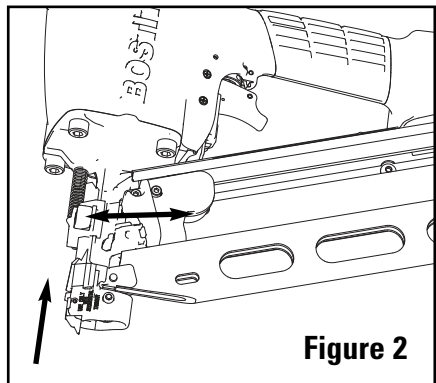
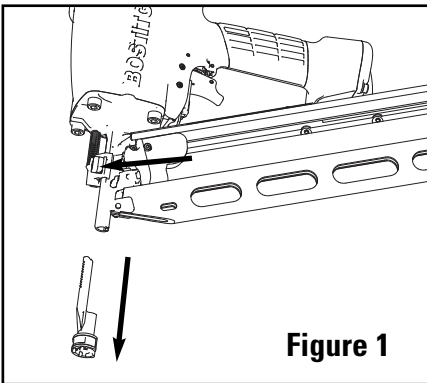

**⚠WARNING:** Always check that the Lower Contact Arm or Metal Connector Attachment moves freely before using tool. If any binding occurs, repeat assembly procedure or have tool serviced at an authorized BOSTITCH service center. For locations call: 1-800-556-6696

If further information is required, call BOSTITCH Customer Service at 1-800-556-6696 or write to: BOSTITCH Customer Service, Briggs Drive, East Greenwich, RI 02818.



# TOOL OPERATION

**⚠WARNING:**

**EYE PROTECTION** which conforms to ANSI specifications and provides protection against flying particles both from the **FRONT** and **SIDE** should **ALWAYS** be worn by the operator and others in the work area when connecting to air supply, loading, operating or servicing this tool. Eye protection is required to guard against flying fasteners and debris, which could cause severe eye injury.



The employer and/or user must ensure that proper eye protection is worn. Eye protection equipment must conform to the requirements of the American National Standards Institute, ANSI Z87.1 and provide both frontal and side protection. **NOTE:** Non-side shielded spectacles and face shields alone do not provide adequate protection.

## **BEFORE HANDLING OR OPERATING THIS TOOL:**

- I. **READ AND UNDERSTAND THE WARNINGS CONTAINED IN THIS MANUAL.**
- II. **REFER TO “TOOL SPECIFICATIONS” IN THIS MANUAL TO IDENTIFY THE OPERATING SYSTEM ON YOUR TOOL.**

There are two available operation modes on these BOSTITCH pneumatic tools. They are:

1. **SEQUENTIAL TRIP OPERATION**
2. **CONTACT TRIP OPERATION**

## **OPERATION**

BOSTITCH offers two types of triggers which operate differently: Sequential Trip (gray trigger) and Contact Trip (black trigger). Each trigger has specific advantages. You should evaluate your particular construction project to determine which trigger is best.

Your tool was shipped from the factory in the Sequential Trip (gray trigger) configuration. It can easily be converted to the Contact Trip (black trigger) mode of operation using this Contact Trip conversion kit.

### **1. SEQUENTIAL TRIP OPERATION (GRAY TRIGGER):**

The Sequential Trip (gray trigger) gets its name from the “sequence” required to drive a fastener. To drive a fastener, the operator must first depress the “trip” **FULLY** against the work surface and then pull the trigger. To drive a second nail, the operator must lift the tool from the work surface, release the trigger and then repeat the above sequence.

1. **The Sequential Trip (gray trigger):** offers a positive safety advantage since it will not accidentally drive a fastener if the tool is bumped against any surface or anybody while the operator is holding the tools with the trigger pulled.
2. **The Sequential Trip (gray trigger):** allows “place nailing” without the possibility of driving a second, unwanted fastener on recoil as described below under “Contact Trip”.

### **2. CONTACT TRIP OPERATION (BLACK TRIGGER):**

Your new BOSTITCH tool can be configured for use in Contact Trip “Conventional trip” mode. To drive a nail, the “trip” and the trigger must both be depressed. In conventional Contact Trip tools, the trigger may be depressed and held, and each “contact” between the trip and the work surface will drive a nail.

**A. SINGLE FASTENER PLACEMENT (Place Nailing)** -- First position the “trip” **FULLY** on the work surface, **WITHOUT PULLING THE TRIGGER**. Depress the “trip” **FULLY** until the nose of the tool touches the work surface and then pull the trigger to drive a nail. Do not press the tool against the work surface with extra force. Instead, allow the tool to recoil off the work surface to avoid a second unwanted fastener. **Note:** remove your finger from the trigger after each operation.

**B. RAPID FIRE OPERATION (“Bump” Nailing)** – First, hold the tool with the “trip” pointing towards but not touching the work surface. Pull the trigger and then tap or “bump” the trip against the work surface using a bouncing motion. Each depression of the “trip” will cause a nail to be driven.

## **TOOL OPERATION (CONTINUED)**

---

- ⚠WARNING:** The Contact Trip (black) will not prevent a nail from being accidentally driven if the trigger is depressed and the “trip” is bumped against any object or person. Never hold or carry the tool with your finger on the trigger. Only depress and hold trigger when you intend to rapidly drive multiple nails and the tool is pointed at the work surface.
- ⚠WARNING:** Never use contact trigger (black trigger) with metal connector attachment. Only use sequential trigger (gray trigger) with metal connector attachment. Refer to trigger conversion instruction included in the kit.
- ⚠WARNING:** When using conventional Contact Trip for Place Nailing, the tool may bounce due to recoil, and if the tool is allowed to re-contact the work surface while you are holding the trigger pulled, a second unwanted nail will be driven. You should allow the tool to recoil far enough to release the trip and avoid a second cycle. Don't push the tool down extra hard; let the tool do the work.
- ⚠WARNING:** The operator must not hold the trigger pulled on contact trip tools except during fastening operation, as serious injury could result if the trip accidentally contacted someone or something, causing the tool to cycle.
- ⚠WARNING:** Keep hands and body away from the discharge area of the tool. A contact trip tool may bounce from the recoil of driving a fastener and an unwanted second fastener may be driven, possibly causing injury.
- ⚠WARNING:** Never use rafter hook to hang tool from body, clothing or belt.

# OPERATING YOUR F21PL, F21PL2, F33PT & F33PTSM TOOL WITH METAL CONNECTOR ATTACHMENT

**WARNING:**



**EYE PROTECTION** which conforms to ANSI specifications and provides protection against flying particles both from the **FRONT** and **SIDE** should **ALWAYS** be worn by the operator and others in the work area when connecting to air supply, loading, operating or servicing this tool. Eye protection is required to guard against flying fasteners and debris, which could cause severe eye injury.

**WARNING:**

The employer and/or user must ensure that proper eye protection is worn. Eye protection equipment must conform to the requirements of the American National Standards Institute, ANSI Z87.1 and provide both frontal and side protection. **NOTE:** Non-side shielded spectacles and face shields alone do not provide adequate protection.

**IMPORTANT - READ CAREFULLY!**

You and others working around you can be seriously injured by this tool if you do not follow the instructions provided on the tool and in the operation manual. Used properly, the tool provides an easy, safe, and efficient method for driving nails for all kinds of construction projects.

**NOTE:** Refer to your Operation Manual or Parts List if any of the terms used below are unfamiliar to you.

- MCN-KIT3 must be purchased separately for the F21PL2 to be used for fastening metal connectors.

## SEQUENTIAL TRIP

**WARNING:**

**Never use contact trigger (black trigger) with metal connector attachment. Only use sequential trigger (gray trigger) with metal connector attachment. Refer to trigger conversion instruction included in the kit.**

The BOSTITCH F21PL, F33PT & F33PTSM tools with Metal Connector Attachment come with the Sequential Trip (gray trigger) installed. This style of trigger:

1. Offers a positive safety advantage since it will not accidentally drive a nail if the tool is bumped against any surface or anybody while the operator is holding the tool with the trigger pulled.
2. Allows Place Nailing without the possibility of driving a second nail on recoil.

The Sequential Trip (gray trigger) gets its name from the "sequence" required to operate the tool. To drive a nail, the operator must first depress the trip against the work surface and then pull the trigger. To drive a second nail, the operator must lift the tool from the work surface, release the trigger, and then repeat the above sequence.

**WARNING:**

**TO AVOID SERIOUS INJURY FROM FASTENERS AND FLYING DEBRIS WHEN INSTALLING METAL CONNECTORS USING THE F21PL, F21PL2, F33PT & F33PTSM WITH METAL CONNECTOR ATTACHMENT:**

- Always use the Metal Connector Attachment. (See installation instructions.)
- Only use sequential trip (gray trigger).
- Use only genuine BOSTITCH metal connector nails.
- Use only one stick of metal connector nails at a time.
- Metal connector nails are not designed to penetrate metal. When installing metal connectors, always place the Metal Connector Attachment Guide in the metal connector's pre-formed hole before attempting to drive a fastener

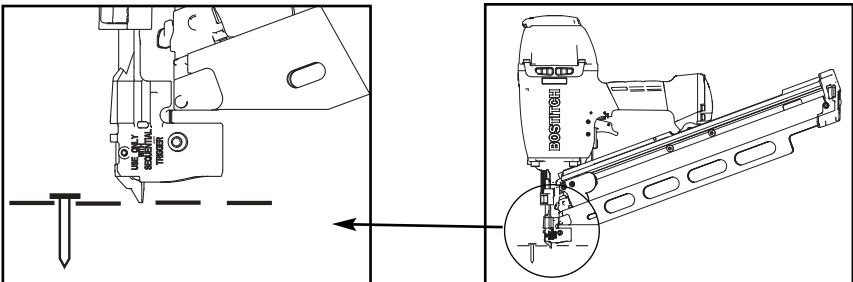

**WARNING:**

When installing Metal Connectors, use **ONLY BOSTITCH Heat Treated Metal Connector Nails**

## **TOOL OPERATION CHECK:**

---

**CAUTION:** Remove all fasteners from tool before performing tool operation check.

### **1. SEQUENTIAL TRIP OPERATION:**

- A. Press the contact trip against the work surface, without touching the trigger.  
**THE TOOL MUST NOT CYCLE.**
- B. Hold the tool off the work surface and pull the trigger.  
**THE TOOL MUST NOT CYCLE.**  
Release the trigger. The trigger must return to the trigger stop on the frame.
- C. Pull the trigger and press the contact trip against the work surface.  
**THE TOOL MUST NOT CYCLE.**
- D. With finger off the trigger, press the contact trip against the work surface. Pull the trigger.  
**THE TOOL MUST CYCLE.**

### **2. CONTACT TRIP OPERATION:**

- A. With finger off the trigger, press the contact trip against the work surface.  
**THE TOOL MUST NOT CYCLE.**
- B. Hold the tool off the work surface, and pull the trigger.  
**THE TOOL MUST NOT CYCLE.**
- C. With the tool off the work surface, pull the trigger. Press the contact trip against the work surface.  
**THE TOOL MUST CYCLE.**
- D. Without touching the trigger, press the contact trip against the work surface, then pull the trigger.  
**THE TOOL MUST CYCLE.**

## **IN ADDITION TO THE OTHER WARNINGS CONTAINED IN THIS MANUAL OBSERVE THE FOLLOWING FOR SAFE OPERATION**

- Use the BOSTITCH pneumatic tool only for the purpose for which it was designed.
- Never use this tool in a manner that could cause a fastener to be directed toward the user or others in the work area.
- Do not use the tool as a hammer.
- Always carry the tool by the handle. Never carry the tool by the air hose.
- Do not alter or modify this tool from the original design or function without approval from BOSTITCH
- Always be aware that misuse and improper handling of this tool can cause injury to yourself and others.
- Never clamp or tape the trigger or contact trip in an actuated position.
- Never leave a tool unattended with the air hose attached.
- Do not operate this tool if it does not contain a legible WARNING LABEL.
- Do not continue to use a tool that leaks air or does not function properly. Notify your nearest BOSTITCH representative if your tool continues to experience functional problems.

# **MAINTAINING THE PNEUMATIC TOOL**

**⚠WARNING:** When working on air tools, note the warnings in this manual and use extra care evaluating problem tools.

**CAUTION:** Pusher spring (constant force spring). Caution must be used when working with the spring assembly. The spring is wrapped around, but not attached to, a roller. If the spring is extended beyond its length, the end will come off the roller and the spring will roll up with a snap, with a chance of pinching your hand. Also the edges of the spring are very thin and could cut. Care must also be taken to insure no permanent kinks are put in the spring as this will reduce the springs force.

## **REPLACEMENT PARTS:**

BOSTITCH replacement parts are recommended. Do not use modified parts or parts which will not give equivalent performance to the original equipment.

## **ASSEMBLY PROCEDURE FOR SEALS:**

When repairing a tool, make sure the internal parts are clean and lubricated. Use Parker "O"-LUBE or equivalent on all "O"-rings. Coat each "O"-ring with "O"-LUBE before assembling. Use a small amount of oil on all moving surfaces and pivots. After reassembly add a few drops of BOSTITCH Air Tool Lubricant through the air line fitting before testing.

## **AIR SUPPLY-PRESSURE AND VOLUME:**

Air volume is as important as air pressure. The air volume supplied to the tool may be inadequate because of undersize fittings and hoses, or from the effects of dirt and water in the system. Restricted air flow will prevent the tool from receiving an adequate volume of air, even though the pressure reading is high. The results will be slow operation, misfeeds or reduced driving power. Before evaluating tool problems for these symptoms, trace the air supply from the tool to the supply source for restrictive connectors, swivel fittings, low points containing water and anything else that would prevent full volume flow of air to the tool.

# TROUBLE SHOOTING

<b>PROBLEM</b>	<b>CAUSE</b>	<b>CORRECTION</b>
Trigger valve housing leaks air	O-ring cut or cracked	.Replace O-ring
Trigger valve stem leaks air	O-ring/seals cut or cracked	.Replace trigger valve assembly
Frame/nose leaks air	Loose nose screws	.Tighten and recheck
	O-ring or Gasket is cut or cracked	.Replace O-ring or gasket
	Bumper cracked/worn	.Replace bumper
Frame/cap leaks air	Damaged gasket or seal	.Replace gasket or seal
	Cracked/worn head valve bumper	.Replace bumper
	Loose cap screws	.Tighten and recheck
Failure to cycle	Air supply restriction	.Check air supply equipment
	Tool dry, lack of lubrication	.Use BOSTITCH Air Tool Lubricant
	Worn head valve O-rings	.Replace O-rings
	Broken cylinder cap spring	.Replace cylinder cap spring
	Head valve stuck in cap	.Disassemble/Check/Lubricate
Lack of power; slow to cycle	Tool dry, lacks lubrication	.Use BOSTITCH Air Tool Lubricant
	Broken cylinder cap spring	.Replace cap spring
	O-rings/seals cut or cracked	.Replace O-rings/seals
	Exhaust blocked	.Check bumper, head valve spring, muffler
	Trigger assembly worn/leaks	.Replace trigger assembly
	Dirt/tar build up on driver	.Disassemble nose/driver to clean
	Cylinder sleeve not seated correctly on bottom bumper	.Disassemble to correct
	Head valve dry	.Disassemble/lubricate
	Air pressure too low	.Check air supply equipment
Skipping fasteners; intermittent feed	Worn bumper	.Replace bumper
	Tar/dirt in driver channel	.Disassemble and clean nose and driver
	Air restriction/inadequate air flow through quick disconnect socket and plug	.Replace quick disconnect fittings
	Worn piston O-ring	.Replace O-ring, check driver
	Tool dry, lacks lubrication	.Use BOSTITCH Air Tool Lubricant
	Damaged pusher spring	.Replace spring
	Low air pressure	.Check air supply system to tool
	Loose magazine nose screws	.Tighten all screws
	Fasteners too short for tool	.Use only recommended fasteners
	Bent fasteners	.Discontinue using these fasteners
	Wrong size fasteners	.Use only recommended fasteners
	Leaking head cap gasket	.Tighten screws/replace gasket
	Trigger valve O-ring cut/worn	.Replace O-ring
	Broken/chipped driver	.Replace driver (check piston O-ring)
	Dry/dirty magazine	.Clean/lubricate use BOSTITCH Air Tool Lubricant
	Worn magazine	.Replace magazine
Fasteners jam in tool	Driver channel worn	.Replace nose
	Wrong size fasteners	.Use only recommended fasteners
	Bent fasteners	.Discontinue using these fasteners
	Loose magazine/nose screws	.Tighten all screws
	Broken/chipped driver	.Replace driver
Fastener misses metal connector hole (For F21PL, F33PT)	Broken / chipped guide	.Replace guide
	Broken / missing 158457 torsion spring	.Replace torsion spring (grease before installation)
	Broken Pendulum	.Replace pendulum and torsion spring
	Broken 158455 pin	.Replace pin and torsion spring

# INTRODUCCIÓN

Las herramientas BOSTITCH son herramientas construidas a precisión, diseñadas para clavar con exactitud un alto volumen de clavos. Estas herramientas entregan un servicio eficiente y fiable cuando se usan correctamente y con cuidado. Al igual que con toda herramienta automática de calidad, deben seguirse las instrucciones del fabricante para obtener el óptimo rendimiento. Estudie este manual antes de operar la herramienta y tome nota de las advertencias y precauciones de seguridad. Deben leerse en detalle las instrucciones sobre la instalación, operación y mantenimiento, y debe conservarse el manual para referencia. NOTA: Pueden necesitarse medidas adicionales de seguridad según la aplicación particular de la herramienta. Diríjase al representante o distribuidor de Bostitch si tiene alguna pregunta referente a la herramienta y su uso. BOSTITCH, East Greenwich, Rhode Island 02818

## ÍNDICE

Instrucciones de seguridad .....	16
Especificaciones de la herramienta .....	17
Suministro de aire: Accesorios, mangueras, filtros, consumo de aire, reguladores, Presión operativa, ajuste de la presión correcta .....	17, 18
Lubricación .....	18
Carga de la herramienta, .....	19
Instalación de la vara de guía.....	19
Ajuste de control de profundidad del clavo .....	20
Extracción de clavos, escape direccional .....	20
Instalación del aditamento para el conector de metal .....	21
Funcionamiento de la herramienta .....	22, 23, 24 & 25
Mantenimiento de la herramienta neumática .....	26
Solución de problemas .....	27

## NOTA:

Las herramientas BOSTITCH se han diseñado para brindar una satisfacción excelente al cliente y lograr máximo rendimiento al utilizarse con fijaciones de precisión Bostitch diseñadas con las mismas normas estrictas. **La F33PT, F33PTSM, con el brazo de contacto estándar de enmarcado está diseñada para usarse con barras de papel de clavos de 33°.** La F33PT, F33PTSM, con el aditamento para conectores de metal instalado, está diseñada para usarse con clavos de 35° de conector metálico BOSTITCH. La F21PL y la F21PL2, con el brazo de contacto estructural estándar están diseñadas para usarse con barras plásticas secuenciales de clavos de 21°. La F21PL y la F21PL2, con el aditamento opcional para conectores de metal instalado, están diseñadas para usarse con clavos de conector metálico Bostitch de 23°. BOSTITCH no puede asumir responsabilidad alguna por el rendimiento del producto si se utilizan nuestras herramientas con fijaciones o accesorios que no reúnen los requisitos específicos establecidos para los clavos, grapas y accesorios genuinos de BOSTITCH.



## GARANTÍA LIMITADA – Sólo EE.UU. y Canadá

A partir del 1 de diciembre de 2005 Bostitch, L.P. garantiza al comprador del comerciante original que el producto comprado está exento de defectos en material y fabricación, y se compromete a reparar o reemplazar, a opción de Bostitch, cualquier engrapadora o clavadora neumática defectuosa de marca Bostitch por un período de siete (7) años desde la fecha de compra (un (1) año de la fecha de compra en el caso de compresores y herramientas utilizadas en aplicaciones de producción). La garantía no es transferible. Se requiere presentar evidencia de la fecha de compra. Esta garantía solamente cubre daños resultantes de defectos en material o fabricación, y no cubre condiciones o desperfectos resultantes del desgaste normal, negligencia, abuso, accidente o reparaciones intentadas o efectuadas por terceros ajenos a nuestro centro nacional de reparaciones o a los centros de servicio bajo garantía. Las aspas del impulsor, topes, juntas tóricas, pistones y aros de pistones se consideran componentes de desgaste normal. Para obtener el rendimiento óptimo de la herramienta Bostitch siempre use fijaciones y piezas de repuesto genuinas de Bostitch.

ESTA GARANTÍA SUSTITUYE TODA OTRA GARANTÍA, EXPRESA O IMPLÍCITA, INCLUIDAS ENTRE OTRAS, LAS GARANTÍAS IMPLÍCITAS DE COMERCIABILIDAD O IDONEIDAD PARA UN FIN PARTICULAR. BOSTITCH NO SERÁ RESPONSABLE DE DAÑOS FORTUITOS O CONSECUENCIALES.

Algunos estados y países no permiten limitaciones a la duración de una garantía implícita ni la exclusión o limitación de daños fortuitos o consecuenciales, de modo que las limitaciones o exclusiones anteriores pueden no corresponder a su caso. Esta garantía le concede derechos legales específicos, y usted puede tener también otros derechos que varían de un estado a otro y de un país a otro.

Para obtener servicio bajo garantía en los EE.UU. devuelva el producto, junto con el comprobante de compra, al Centro de Servicio bajo Garantía Autorizado Independiente Nacional o Regional de Bostitch en los EE.UU. Dentro de los EE.UU. usted puede llamarnos al 1-800-556-6696 o visitar [www.BOSTITCH.com](http://www.BOSTITCH.com) para ver la ubicación que más le convenga. En Canadá llámenos al at 1-800-567-7705 o visite [www.BOSTITCH.com](http://www.BOSTITCH.com).